

auto electrical parts

Technical Information Sheet

Part No. 0-525-15

12/24 volt 50° to 150°C marine oil temperature gauge, 90° sweep dial. LED illumination, plastic cased with screw collar type fitting. Supplied with 1/8" NPTF sender.

Additional Information

Illumination white. Sender has common earth and single 6.3mm lucar blade, replacement part 0-525-85.



Technical Drawing (not to scale)

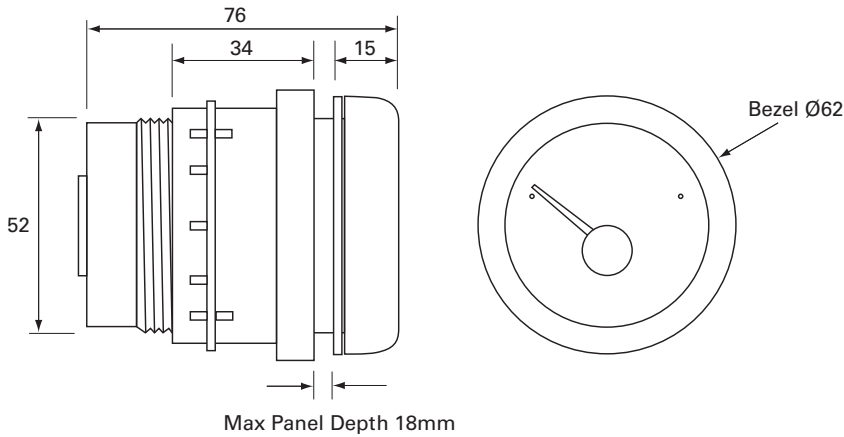

Sender unit

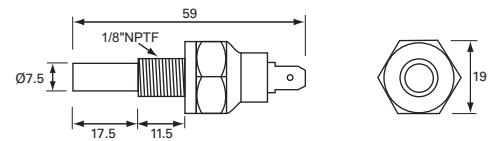

Specification

Type	Panel mount marine oil temperature gauge
Voltage	12/24 volt DC
Scale	90° sweep, 50° to 150°C
Illumination	4 LED white
LED current	33mA
Cable length	520mm
Panel Cut out	52mm
Max panel depth	18mm
Protection	IP65 (front)
Weight	190g (inc. sender)
Dimensions	See diagram

Sender

Resistance	208 - 9.8Ω
Material	Copper
Thread	1/8" NPTF

The information contained in this document is correct to the best of our knowledge at the time of printing. However, specifications may change at any time without notice.